

**OPTOMETRY
ADMISSION
TESTING
PROGRAM**

SAMPLE TEST

NEW VERSION

**Optometry Admission Testing Program
211 East Chicago Avenue
6th Floor
Chicago, Illinois 6011-2678
1/800-232-2159**

TABLE OF CONTENTS

OPTOMETRY ADMISSION TEST PREPARATION MATERIALS	3
SAMPLE TEST	5
Survey of the Natural Sciences	5
Reading Comprehension	22
Physics	25
Quantitative Reasoning	31
Answers.....	37
ESTIMATING YOUR STANDARD SCORE	38
Raw-Score Standard Score Conversions	40

Copyright © 2006 All rights reserved. This document contains copyrighted material, which is reprinted with permission of the copyright owner. Any copying, reproduction or republishing of this document, in whole or in part, is strictly prohibited.

Printed in U.S.A.

OPTOMETRY ADMISSION TEST PREPARATION MATERIALS

How does one prepare for the OAT? There are no shortcuts to the process of learning, and these test preparation materials are not designed to provide the examinee with an opportunity to bypass the extensive process of learning and understanding basic information through class participation and months of study. These test preparation materials contain samples of the four tests used in the Optometry Admission Testing Program. These are available to OAT examinees as a means of discovering possible areas of weakness in their comprehension of subjects covered by the test. They will also enable the examinee to become familiar with the types of material included in the test as well as with the general coverage and format of the various parts of the test battery.

The Optometry Admission Testing Program may include pretest questions in some test sections. Un-scored pretest questions are included on the test in order to ensure that these questions are appropriate before they are included among the scored items. If pretest questions are included in a test section, additional time will be allotted to that section of the test. Pretest questions are intermingled with the scored questions; therefore it is important to answer all questions.

Total Testing Time

Test Section	Time Limit
Tutorial	15 minutes
Survey of the Natural Sciences	90 minutes
Reading Comprehension Test	50 minutes
Break (optional)	15 minutes
Physics Test	50 minutes
Quantitative Reasoning Test	45 minutes
Post Test Survey	10 minutes
Pre testing	up to 25 minutes
Total Time	275 to 300 minutes depending on the number of pretest questions

The time limit is indicated on the computer screen for each section. If pretest questions are included in a test section, additional time will be allotted to that section of the test. The Survey of the Natural Sciences and the Reading Comprehension Test are administered first. The Physics Test and the Quantitative Reasoning Test are administered after an optional 15 minute rest break.

The **Survey of the Natural Sciences** is an achievement test. The content is limited to those areas covered by an entire first-year course in biology, general chemistry, and organic chemistry. The test contains a total of 100 items: 40 biology items, 30 general chemistry items and 30 organic chemistry items. The time limit of the test is 90 minutes. Although the three science sections are identified, it is important that the examinees pace themselves since separate sub scores will be given for each section.

The **Reading Comprehension Test** contains passages typical of the level of material encountered in the first year of optometry school. Each passage is followed by 10 to 17 items, which can be answered from a reading of the passage. One should not try to answer the questions until the passage is understood thoroughly. The time limit of the test is 50 minutes. Although these materials contain only one passage, the actual Reading Comprehension Test contains three passages and has a total of 40 items.

The **Physics Test** is also an achievement test. The content is limited to those areas covered in a two-semester physics course. The test contains a total of 40 items. The time limit of the test is 50 minutes.

The **Quantitative Reasoning Test** measures the examinee's ability to reason with numbers, to manipulate numerical relationships, and to deal intelligently with quantitative materials. The test contains 40 items. The time limit of the test is 45 minutes. Calculators are not permitted.

The answers for each practice test and a raw score/standard score conversion table are all located at the end of these test preparation materials. By locating the number of correct answers you selected on each test, you will be able to determine your standard score.

Another valuable guide for individuals preparing to apply to optometry school is *Optometry A Career with Vision*. This publication, which is available from the American Optometric Association, 243 N. Lindbergh Blvd., St. Louis, MO 63141, contains useful information concerning specific optometry school prerequisites, financial assistance, the costs of an optometry education, and other areas of interest to the prospective optometry student.

This is the **ONLY** edition of these preparation materials available.

Optometry
Admission
Testing
Program

211 East Chicago Avenue
Sixth Floor
Chicago, Illinois 60611-2678
(800) 232-2159

Survey of the Natural Sciences Sample Test

Time Limit: 90 minutes

PERIODIC TABLE OF THE ELEMENTS

1	PERIODIC TABLE OF THE ELEMENTS																18
IA																	Noble gases
																	VIIIA
1 H 1.01	2 IIA											13 IIIA	14 IVA	15 VA	16 VIA	17 VIIA	2 He 4.00
3 Li 6.94	4 Be 9.01											5 B 10.81	6 C 12.01	7 N 14.01	8 O 16.00	9 F 19.00	10 Ne 20.18
11 Na 22.99	12 Mg 24.31	3 IIIB	4 IVB	5 VB	6 VIB	7 VII B	8 VIII B			11 IB	12 IIB	13 Al 26.98	14 Si 28.09	15 P 30.97	16 S 32.07	17 Cl 35.45	18 Ar 39.95
19 K 39.10	20 Ca 40.08	21 Sc 44.96	22 Ti 47.83	23 V 50.94	24 Cr 52.00	25 Mn 54.94	26 Fe 55.85	27 Co 58.93	28 Ni 58.71	29 Cu 63.55	30 Zn 65.39	31 Ga 69.72	32 Ge 72.61	33 As 74.92	34 Se 78.96	35 Br 79.90	36 Kr 83.80
37 Rb 85.47	38 Sr 87.62	39 Y 88.91	40 Zr 91.22	41 Nb 92.91	42 Mo 95.94	43 Tc (98)	44 Ru 101.07	45 Rh 102.91	46 Pd 106.42	47 Ag 107.87	48 Cd 112.41	49 In 114.82	50 Sn 118.71	51 Sb 121.76	52 Te 127.60	53 I 126.90	54 Xe 131.29
55 Cs 132.91	56 Ba 137.33	57 La 138.91	72 Hf 178.49	73 Ta 180.95	74 W 183.85	75 Re 186.21	76 Os 190.20	77 Ir 192.20	78 Pt 195.08	79 Au 196.97	80 Hg 200.59	81 Tl 204.39	82 Pb 207.20	83 Bi 208.98	84 Po (209)	85 At (210)	86 Rn (222)
87 Fr (223)	88 Ra 227.03	89 Ac (227)	104 Rf (261)	105 Db (262)	106 Sg (263)	107 Bh (262)	108 Hs (265)	109 Mt (266)	110 (264)	111 (272)	112 (277)			114 (289)			116 (289)
Lanthanides		58 Ce 140.12	59 Pr 140.91	60 Nd 144.24	61 Pm 145.00	62 Sm 150.36	63 Eu 151.97	64 Gd 157.25	65 Tb 158.93	66 Dy 162.50	67 Ho 164.93	68 Er 167.26	69 Tm 168.93	70 Yb 173.04	71 Lu 174.97		
Actinides		90 Th 232.04	91 Pa 231.04	92 U 238.03	93 Np (237)	94 Pu (244)	95 Am (243)	96 Cm (247)	97 Bk (247)	98 Cf (251)	99 Es (252)	100 Fm (257)	101 Md (258)	102 No (259)	103 Lr (260)		

This examination is comprised of 100 items:

Biology (1-40)

1. According to the second law of thermodynamics
- A. energy can neither be created or destroyed.
 - B. energy can be created or destroyed.
 - C. any system isolated from an energy source tends to decrease in entropy.
 - D. organisms could not evolve.
 - E. any system isolated from an energy source tends toward its least ordered state.
2. Two identical tubes of yeast are growing in a sugar solution. One tube is sealed, one is left open to the air. The sealed tube will differ from the open one in that the yeast in the sealed tube will produce more
- A. acetyl CoA.
 - B. ATP per glucose
 - C. ethanol.
 - D. lactic acid.
 - E. CO₂ per glucose.

3. Organisms that obtain their energy from light can be termed
- A. autotrophic.
 - B. holotrophic.
 - C. chemotrophic.
 - D. heterotrophic.
 - E. heliotrophic.
4. Which part of a microscope magnifies the image of the specimen being examined?
- A. Condenser
 - B. Illuminator
 - C. Fine focus
 - D. Objective
 - E. Stage

5. An investigator isolates small particles from cancer cells and places these particles into an equal mixture of radioactive proteins and amino acids. The amount of radioactive proteins (dotted line) and amino acids (solid line) is then measured over time (graph). Based on the data, what are the particles?

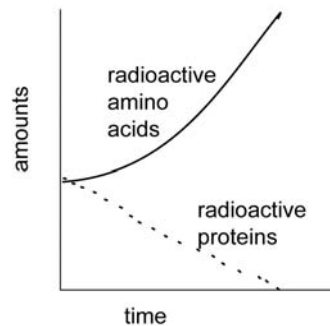

- A. Ribosomes
 - B. Lipid vacuoles
 - C. Lysosomes
 - D. Food vacuoles
 - E. Mitochondria
6. The endosymbiotic theory states that
- A. eukaryotic cells possess the ability to reproduce sexually.
 - B. eukaryotic cells live in associations called colonies.
 - C. eukaryotic cells incorporate a prokaryotic cell.
 - D. prokaryotic cells consist of a network of internal membranes.
 - E. prokaryotic cells live in associations called colonies.
7. Indirect immunofluorescence microscopy is used to stain cells for ATP synthase. Which of the following will then be fluorescent?
- A. Mitochondria
 - B. Nucleus and nuclear envelope
 - C. Cytoplasm
 - D. Golgi apparatus
 - E. Endoplasmic reticulum

8. Messenger ribonucleic acid (mRNA) differs from deoxyribonucleic acid (DNA) in that mRNA
- contains thymine instead of uracil.
 - contains ribose sugar.
 - is single-stranded.
 - contains thymine instead of uracil and is single-stranded
 - contains ribose sugar and is single-stranded.
9. What is the first event that occurs during meiosis?
- Homologous chromosomes segregate to opposite poles.
 - Sister chromatids segregate to opposite poles.
 - Homologous chromosomes align at the midplate of the cell.
 - Homologous chromosomes pair and synapse.
 - Chromosomes condense in a diploid nucleus.
10. If animal muscle cells are deprived of oxygen, anaerobic glycolysis will result and pyruvic acid will then be converted to
- alcohol.
 - glucose.
 - lactic acid.
 - phosphoric acid.
 - acetyl CoA.
11. A sample of blood is added to a test tube containing a 1.6% salt solution. A short while later, the red blood cells are observed to be smaller and wrinkled in shape due to water loss. This indicates that
- red blood cells are isotonic to the 1.6% salt solution.
 - red blood cells are hypertonic to the 1.6% salt solution.
 - red blood cells are hypotonic to the 1.6% salt solution.
 - the 1.6% salt solution is hypotonic to the red blood cells.
 - the 1.6% salt solution is isotonic to the red blood cells.
12. Which of the following types of lipids are associated with the plasma membrane of eukaryotic but not prokaryotic cells?
- Glycolipids
 - Phosphoglycerides
 - Sphingolipids
 - Steroids
 - Vitamins
13. A plant kept in the dark will not be able to produce glucose because light is necessary
- for the oxidation of glucose.
 - to excite electrons in the CO_2 molecules.
 - for activating enzymes necessary for converting CO_2 to glucose.
 - for sufficient ATP and reduced NADP to be available to synthesize glucose from CO_2 .
 - for glucose phosphorylation.
14. The first law of thermodynamics implies that living organisms cannot create their own energy but can only convert one form of energy into another. What, then, is the ultimate source of energy for most living organisms?
- Chemical energy from the glucose molecule made by plants during photosynthesis
 - The chemical energy released by the numerous hydrolytic reactions in a cell
 - Heat energy from the sun
 - Light energy from the sun
 - ATP made in the mitochondria of both plants and animals
15. Which of the following is not a known function of any hormone?
- Affects membrane transport of substances
 - Regulates water balance in the body
 - Changes the amount of activity of enzymes
 - Promotes transcription of messenger RNA
 - Acts as a source of energy

16. Which of the following pairs of structures have similarity of function?

- A. Thyroid gland and sympathetic nervous system
- B. Adrenal cortex and sympathetic nervous system
- C. Adrenal cortex and parasympathetic nervous system
- D. Adrenal medulla and parasympathetic nervous system
- E. Adrenal medulla and sympathetic nervous system

17. In the nephron of the kidney, filtration occurs between

- A. Bowman's capsule and Henle's loop.
- B. the glomerulus and Bowman's capsule.
- C. the proximal tubule and Henle's loop.
- D. Henle's loop and the vasa recta.
- E. the peritubular network and the convoluted tubules.

18. The stimulation of parasympathetic nerves would produce

- A. an increase in peristaltic activity.
- B. an increase in perspiration.
- C. a decrease in salivary gland activity.
- D. an increase in blood pressure.

19. Which of the following situations is most likely to result in genetic drift?

- A. An increase in population size
- B. A lack of gene mutation
- C. A prevention of emigration
- D. Random mating
- E. Isolation of a small population from a larger one

20. An experiment was conducted to compare the effects of three unidentified compounds on the clotting of blood drawn from a patient with hemophilia. The results of this experiment are shown below:

Substance	Level of Clotting
A	-
B	-
C	+++

Based on the data shown, substance "C" is exhibiting properties similar to which of the following?

- A. Globulin
- B. Sodium
- C. Hemoglobin
- D. Fibrin
- E. IgG

21. The muscle cells of the human heart are primarily nourished by

- A. blood within the four chambers of the heart.
- B. fluid in the pericardial cavity.
- C. the lymphatic system.
- D. blood delivered by the coronary arteries.
- E. blood delivered by the ductus arteriosus.

22. Carbon dioxide passes from tissues to blood to lungs by

- A. diffusing from a region of high concentration to an area of lesser concentration.
- B. diffusing from a region of lower to one of higher concentration.
- C. active transport.
- D. irreversibly binding hemoglobin.
- E. chemiosmosis.

- 23.** A person eats a muffin containing ^{14}C -labeled carbohydrate. Following digestion where is the first place high levels of radioactivity would accumulate is the
- Heart.
 - Spleen.
 - Pancreas.
 - Liver.
 - Colon.
- 24.** Which of the following are typically autotrophic?
- Protozoa
 - Plants
 - Animals
 - Fungi
 - Bacteria
- 25.** Of the following phyla, the one that contains more species than the others combined is
- Annelida.
 - Arthropoda.
 - Mollusca.
 - Echinodermata.
 - Chordata.
- 26.** The neurotransmitter that signals skeletal muscle fibers to contract is
- acetylcholine.
 - glutamate.
 - glutamine.
 - noradrenaline.
 - serotonin.
- 27.** In which of these kingdoms are the organisms entirely heterotrophic?
- Protista and Fungi
 - Plantae and Fungi
 - Animalia and Fungi
 - Protista and Animalia
 - Monera and Protista
- 28.** Mendel's law of segregation reflects the fact that
- linkage never occurs in peas.
 - alleles segregate differently in males and females.
 - each member of an allelic pair of genes enters a separate cell during meiosis.
 - during the course of development, DNA becomes segregated in the nucleus, RNA in the cytoplasm.
- 29.** A diploid cell ($2N = 20$) has how many tetrads at metaphase I?
- 0
 - 10
 - 20
 - 40
 - 80
- 30.** Sperm are unable to fertilize an egg until they undergo capacitation in the
- vagina.
 - oviduct.
 - prostate.
 - epididymis.
 - seminal vesicle.
- 31.** During the synthesis of a polypeptide the completed polypeptide is released when the
- ribosome reaches a termination codon.
 - ribosome reaches a termination anticodon.
 - tRNAs are depleted.
 - amino acids are depleted.
 - ribosome reaches the 5' end of the mRNA.
- 32.** Twenty four percent of the bases of a double-stranded DNA molecule are adenine (A). What percentage of its bases would be expected to consist of guanine (G)?
- 24
 - 26
 - 48
 - 52
 - 76

33. In the given pedigree, the original parents showing a particular phenotype are most likely

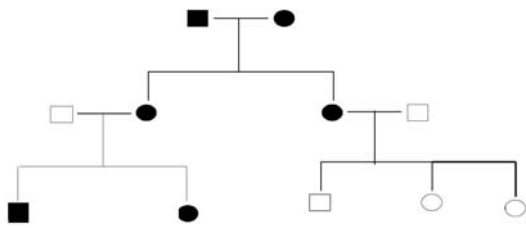

- A. to have produced a mutated gene passed to their daughters.
 B. heterozygous for a sex linked gene.
 C. homozygous dominant for an autosomal trait.
 D. heterozygous dominant for an autosomal trait.
34. One form of colorblindness is caused by gene c carried on the X chromosome in humans. The gene is recessive to its normal allele C. Far more men are colorblind than women. Geneticists explain this by pointing out that
- A. women possess no X chromosomes in their cells.
 B. men carry no genes for color vision on their Y chromosomes.
 C. men carry more genes for colorblindness than women do.
 D. colorblindness is inhibited by female sex hormones.
 E. colorblindness is promoted by male sex hormones.
35. Several generations of 2 species of paramecia are observed reproducing at the same rate. It is noted that population A has fewer phenotypes over time than population B. This most likely would occur if population B
- A. has more surviving offspring.
 B. has fewer individuals with recessive alleles.
 C. reproduces asexually.
 D. reproduces sexually.
 E. has individuals with greater fitness.

36. Gastrulation involves the
- A. formation of the blastocoel.
 B. formation of germ layers.
 C. loss of the blastopore.
 D. formation of the blastula.
 E. final differentiation of the stomach.
37. Of the germ layers comprising the early human embryo, which one forms most of the central nervous system?
- A. Ectoderm
 B. Mesoderm
 C. Endoderm
 D. Notochord
 E. Dermis
38. Embryonic induction is a process in which
- A. embryonic tissues influence adjacent tissues to differentiate.
 B. an unfertilized egg is induced to develop.
 C. genes are transferred from one developing tissue to another.
 D. resting potentials are induced in neurons of embryos.
 E. the maternal parent induces expression of recessive genes in embryos.
39. One of the loveliest sounds in nature is bird song. Such song is commonly associated with
- A. hunger.
 B. pugnacity.
 C. territoriality.
 D. orientation.
40. A deciduous forest biome differs from that of the grassland biome in that the forest biome receives more
- A. sunlight.
 B. CO₂ for photosynthesis.
 C. fixed nitrogen from the soil.
 D. moisture.
 E. ultraviolet light.

41. A sample of gold weighing 38.6 g was added to a graduated cylinder containing 23.00 mL of water. The volume of the water plus the gold was 25.00 mL. What is the density of gold?
- $0.0518 \text{ g} \cdot \text{mL}^{-1}$
 - $2.00 \text{ g} \cdot \text{mL}^{-1}$
 - $19.3 \text{ g} \cdot \text{mL}^{-1}$
 - $38.6 \text{ g} \cdot \text{mL}^{-1}$
 - $1540 \text{ g} \cdot \text{mL}^{-1}$
42. Which of the following solutions will be the best conductor of electricity?
- Glucose in water
 - Glucose in ethanol
 - Table salt in water
 - Table salt in ethanol
43. For the reaction between A and B to form C it is found that when one combines 0.6 moles of A with 0.6 moles of B, all of the B reacts, 0.2 moles of A remain UNREACTED and 0.4 moles of C are produced. What is the balanced equation for this reaction?
- $A + 2B \rightarrow C$
 - $A + 3B \rightarrow 2C$
 - $3A + 3B \rightarrow 2C$
 - $3A + 2B \rightarrow 3C$
 - $2A + 3B \rightarrow 2C$
44. If the mass percent of oxygen in a nitrogen-oxygen compound is known, given the mass percent of oxygen, all of the following are needed to determine the molecular formula of a nitrogen-oxygen compound EXCEPT one. Which one is this EXCEPTION?
- Atomic mass of nitrogen
 - Atomic mass of oxygen
 - Avogadro's number
 - Empirical formula
 - Molar mass of the compound
45. A 10.0 liter sample of oxygen at 100°C and 1 atm is cooled to 27°C and expanded until the pressure is 0.5 atm. Find the final volume of the oxygen.
- $(10.0)(1/5)(27/100)$
 - $(10.0)(1/5)(373/300)$
 - $(10.0)(.5/1)(373/300)$
 - $(10.0)(1/5)(300/373)$
 - $(10.0)(.5/1)(300/373)$
46. When the volume of a gas is decreased at constant temperature, the pressure increases because the molecules
- move faster.
 - experience a lower density.
 - become heavier.
 - become greater in number.
 - strike the container more often.
47. Which of the following types of bonding is found in a diamond?
- Covalent
 - Hydrogen
 - Van der Waal's
 - Metallic
 - Ionic
48. The least electronegative element can be found in the
- upper left corner of the periodic table.
 - upper right corner of the periodic table.
 - lower left corner of the periodic table.
 - lower right corner of the periodic table.
49. The molar volume of copper ($63.5 \text{ g} \cdot \text{mol}^{-1}$) at 25°C is $7.09 \text{ cm}^3 \cdot \text{mol}^{-1}$. Which of the following is the density of copper at 25°C in $\text{g} \cdot \text{cm}^3$?
- $(63.5)/(7.09)$
 - $(63.5)(7.09)$
 - $(7.09)/(63.5)$
 - 7.09
 - $((63.5)/(7.09))(25)$

50. The electrical conductance of two aqueous acidic solutions of the same concentration was measured. The first solution was observed to be a much better conductor than the second. What conclusion can be inferred?
- The pH is the same for both solutions
 - The first solution is a weaker electrolyte than the second
 - The second solution contains a solute that completely ionized when dissolved in water
 - The first solution is a stronger acid than the second
51. Which of the following is not a colligative property?
- Boiling point elevation
 - Sublimation energy
 - Vapor pressure lowering
 - Freezing point depression
 - Osmotic pressure
52. Which of the following will be the final volume when 400mL of 0.6 M HCl is diluted to 0.5 M HCl?
- (400) (0.5/0.6)
 - (400) (0.6/0.5)
 - $((0.6 - 0.5)/1)$ (400)
 - $((1,000-400))$ (0.5/0.6)
 - $(0.6/0.5)$ $((1,000 - 400))$
53. Chlorine bleaches are solutions that contain approximately 5% NaClO. These solutions are
- slightly acidic.
 - strongly acidic.
 - neutral.
 - slightly basic.
 - strongly basic.
54. What is the hydroxide ion concentration, $[OH^-]$, of a solution having a pH of 5.0?
- 5×10^{-5} M
 - 5×10 M
 - 1×10^{-5} M
 - 1×10^{-9} M
 - 5×10^{-9} M
55. Which of the following processes is classified as sublimation?
- $H_2O(l) \rightarrow H_2(g) + (1/2)O_2(g)$
 - $H_2O(g) \rightarrow H_2O(l)$
 - $H_2O(s) \rightarrow H_2(g) + (1/2)O_2(g)$
 - $H_2O(g) \rightarrow H_2O(s)$
 - $H_2O(s) \rightarrow H_2O(g)$
56. For the reaction:
- $$AgCl(s) + 2NH_3(aq) \rightleftharpoons Ag(NH_3)_2^+(aq) + Cl^-(aq),$$
- the equilibrium constant $K = 4 \times 10^{-3}$, which of the following statements is true?
- [K_{sp} for AgCl is 1.0×10^{-10}]
- The addition of NH_3 decreases the solubility of AgCl.
 - AgCl is more soluble in aqueous NH_3 than in water.
 - AgCl is more soluble in aqueous solution containing Cl^- than in water.
 - AgCl is less soluble in aqueous NH_3 than in water.

57. What is the equilibrium constant expression, K, for the gaseous equilibrium:

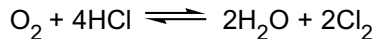

- A. $K = \frac{[\text{H}_2\text{O}]^2[\text{Cl}_2]^2}{[\text{O}_2][\text{HCl}]^4}$
- B. $K = \frac{[\text{H}_2\text{O}][\text{Cl}_2]}{[\text{O}_2][\text{HCl}]}$
- C. $K = \frac{[\text{O}_2][\text{HCl}]^4}{[\text{H}_2\text{O}]^2[\text{Cl}_2]^2}$
- D. $K = \frac{2[\text{H}_2\text{O}]^2[\text{Cl}_2]^2}{[\text{O}_2]^4[\text{HCl}]}$
- E. $K = \frac{2[\text{H}_2\text{O}]^2 2[\text{Cl}_2]^2}{[\text{O}_2]^4[\text{HCl}]^4}$

58. What would be the heat of formation, ΔH_f° , for NO_2 gas if one considers the equations for the following reactions where all substances are gases?

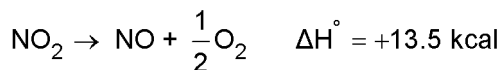
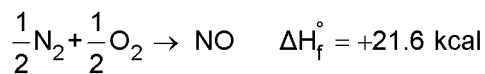

- A. - 28.7 kcal
- B. - 8.1 kcal
- C. 35.1 kcal
- D. 28.7 kcal
- E. 8.1 kcal
59. Which one of the following processes is accompanied by a decrease in entropy?

- A. Freezing of water
- B. Evaporation of water
- C. Sublimation of carbon dioxide
- D. Shuffling a deck of cards
- E. Heating a balloon filled with a gas

60. Rates of reactions are usually studied by

- A. measuring the concentration of the reactants or products as a function of time.
- B. calculating the free energy change for the reaction.
- C. measuring the heat evolved under different conditions.
- D. measuring the amount of each reactant in the reaction.
- E. calculating the entropy change for the reaction.

61. A 0.60 M solution is made by dissolving solid compound X in water. After ten seconds, the concentration of X is 0.40 M. All of the following could account for these results EXCEPT one. Which one is this EXCEPTION?

- A. Precipitation
- B. Neutralization
- C. Evaporation
- D. Decomposition
- E. Disproportionation

62. All chemicals should be handled with care. However, extra precautions should be taken when handling

- A. sodium chloride.
- B. dilute hydrochloric acid.
- C. sodium metal.
- D. sodium sulfate.
- E. calcium carbonate.

63. Given the following half-cell reactions:

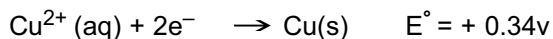
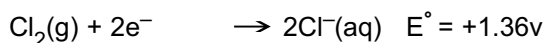

what is the value of E° for the following reaction?

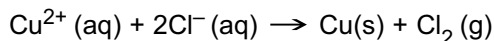

- A. -2.38v
- B. -1.70v
- C. -1.02v
- D. +1.02v
- E. +1.70v

64. Which of the following represents the CHANGE in oxidation state of nitrogen during the chemical reaction?

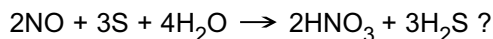

- A. 1
B. 2
C. 3
D. 4
E. 5
65. The ion ${}^9_4\text{Be}^{2+}$ has
- A. 4 protons, 5 neutrons and 4 electrons.
B. 4 protons, 5 neutrons and 2 electrons.
C. 5 protons, 4 neutrons and 2 electrons.
D. 5 protons, 4 neutrons and 4 electrons.
66. The bond length in Cl_2 is 1.99 Å. The distance separating two adjacent carbon nuclei in diamond is 1.54 Å. Based on these data, what is the length of the C-Cl bond in the compound CCl_4 ?
- A. 3.53
B. 2.53
C. 2.16
D. 1.76
E. 1.54
67. Which of the following is the ground state electron configuration for ${}^{24}_{12}\text{Mg}^{2+}$?
- A. $1s^2 2s^2 2p^6 3s^2$
B. $1s^2 2s^2 2p^6$
C. $1s^2 2s^2 2p^6 3s^2 3p^2$
D. $1s^2 2s^2 2p^4 3s^2$
E. $1s^2 2s^2 2p^6 3s^2 3p^6 3d^4 4s^2$

68. Antimony (Sb) has a smaller atomic radius than strontium (Sr) because of
- A. increased electron shielding.
B. the lanthanide contraction.
C. increased metallic character.
D. increased nuclear to electron attraction.
E. the difference in the number of neutrons in their nucleus.

69. Carbon tetrachloride, CCl_4 , is observed to have a higher boiling point than chloroform, CHCl_3 . All of the following statements are true base on this observation EXCEPT one. Which is this EXCEPTION?
- A. Dispersion forces are experienced by CCl_4 and CHCl_3 .
B. At a given temperature, the vapor pressure of CCl_4 is less than that of CHCl_3 .
C. The molar heat of vaporization of CCl_4 is greater than that of CHCl_3 .
D. Dipole-dipole interactions are responsible for the larger boiling point of CCl_4 .

70. In the nuclear reaction:

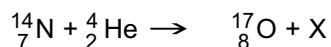

the symbol X represents which of the following?

- A. ${}^4_2\text{He}$
B. ${}^1_0\text{n}$
C. ${}^0_{-1}\text{e}$
D. ${}^0_{+1}\text{e}$
E. ${}^1_1\text{H}$

71. In the reaction energy diagram shown below, what is the intermediate species?

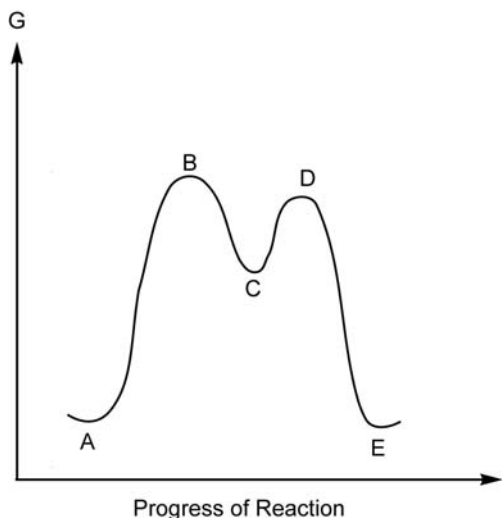

- A. A
B. B
C. C
D. D
E. E

72. A characteristic feature of the S_N2 reaction mechanism is that
- it follows first-order kinetics.
 - it produces stereochemical inversion of configuration.
 - there is no rate-determining step.
 - steric factors have little influence on the reaction rate constant.
 - collision of three or more particles is required.
73. It is believed that an unlabeled bottle containing an unknown liquid is either 2-pentanone or 3-pentanone. What is the best methodology to distinguish one compound from the other?
- Mass Spectroscopy
 - Infrared Spectroscopy
 - ^{13}C NMR Spectroscopy
 - Thin Layer Chromatography
 - Melting Point Determination

74. What is the produce of the following reaction sequence.

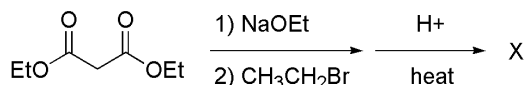

- A.
- B.
- C.
- D.
- E.

75. Which statement is true regarding a compound that has multiple chiral centers and a plane of symmetry?

- It is chiral.
- It is asymmetric.
- It is an enantiomer.
- It is meso.
- It rotates plan polarized light.

76. Nitration of toluene ($\text{Ph}-\text{CH}_3$) with $\text{HNO}_3/\text{H}_2\text{SO}_4$ occurs

- faster than nitration of benzene and produces mostly ortho and para products.
- slower than nitration of benzene and produces mostly meta product.
- faster than nitration of benzene and produces mostly meta product.
- slower than nitration of benzene and produces mostly ortho and para products.
- at the same rate as nitration of benzene and produces mostly meta product.

77. Which of the following carbocations is the most stable?

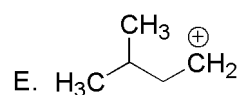
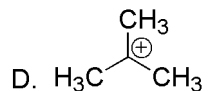
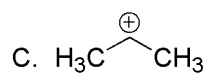
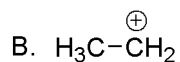
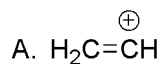

78. Which of the following does a strong infrared absorption band between 1750 and 1700 cm^{-1} (5.77 - 5.88 μm) indicate the presence of?

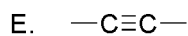
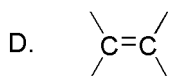
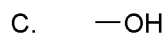
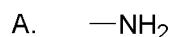

79. According to IUPAC rules, which functional group is given the highest priority when numbering the parent chain?

- A. Amines
- B. Alkenes
- C. Aldehydes
- D. Amides
- E. Acid Anhydrides

80. Which of the compounds below would be most soluble in water?

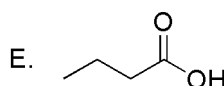
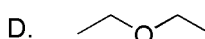
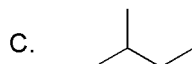
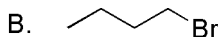
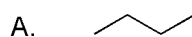

81. Which of the conformations of 1,3-dimethylcyclohexane is the least stable?

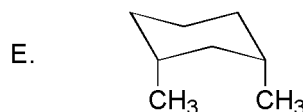
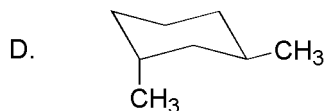
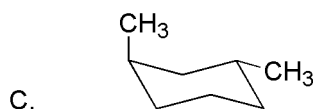
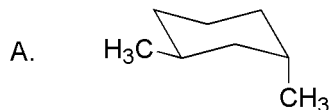

82. Which ONE of the following pure liquids would be expected to show extensive intermolecular hydrogen bonding?

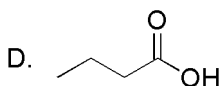
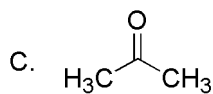
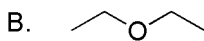
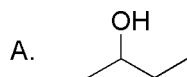

83. Which of the following compounds is a tertiary (3°) amine?

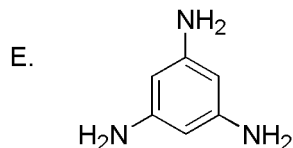
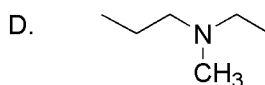
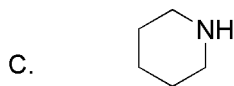
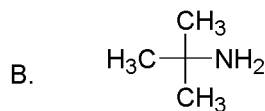
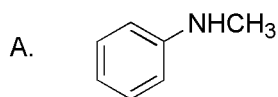

84. Which of the following compounds best fits the ^1H NMR spectral data listed below?

^1H NMR

0.86 ppm (12 H, doublet)
1.06 ppm (2 H, septet)

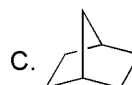
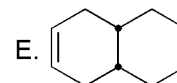
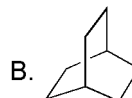
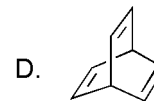

85. Which of the following will undergo a free radical bromination most rapidly?

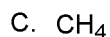
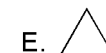
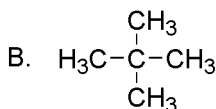
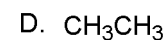
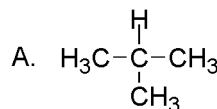

86. How many π molecular orbitals does pyridine possess?

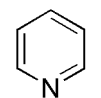

pyridine

- A. 3
B. 4
C. 5
D. 6
E. 7

87. Which combination of reagents will produce

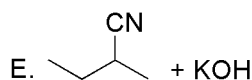
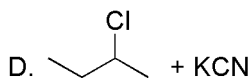
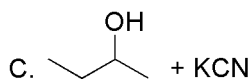
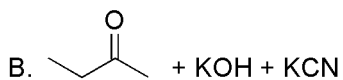
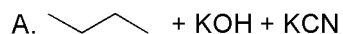
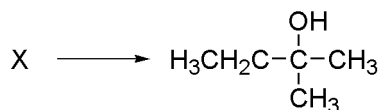

88. Which of the following statements is true regarding a pair of compounds that are diastereomers of each other?

- They are configurational isomers.
- They have the same physical properties.
- They are mirror images.
- They are always optically active.
- They have equal but opposite α values.

89. The indicated H atom on imidazole is acidic. This can best be explained by stabilization of the conjugate base. Which of the following is the greatest cause of this stabilization?

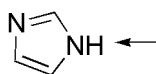

Imidazole

- The inductive effect
- Resonance
- Conjugation
- Aromaticity
- Hyperconjugation

90. What is the product of the following sequence of reactions?

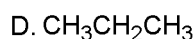
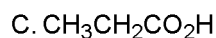
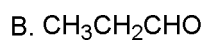
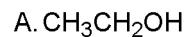
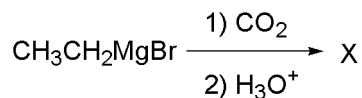

91. Which reagent, followed by the appropriate work-up procedure, could you use to effect the following conversion?

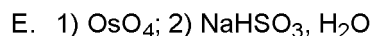
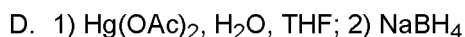
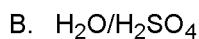
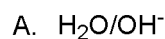
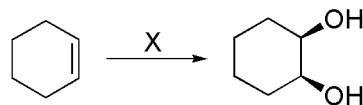

92. What is the product of the following addition reaction?

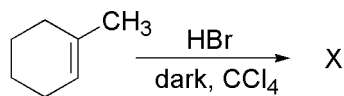

- A.
- B.
- C.
- D.
- E.

93. What is the hybridization of a nitrogen atom if it forms two σ two π bonds?

- A. sp
 B. sp²
 C. sp³
 D. sp³d²

94. Which of the following is a group that is both deactivating and ortho, para directing in the nitration reaction of substituted benzenes?

- A. -COOH
 B. -CH₃
 C. -Br
 D. -NO₂
 E. -OCH₃

95. Which of the following functional groups can act as both a Brønsted acid and Brønsted base?

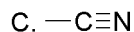

96. What is the major product of the following reaction?

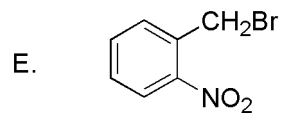
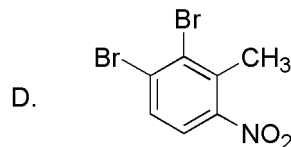
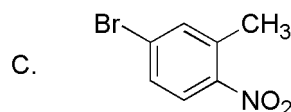
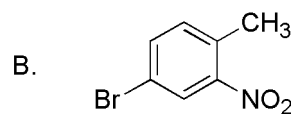
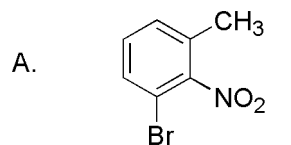
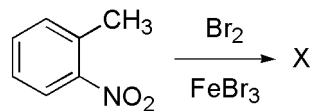

97. Which of the following ions is stabilized by resonance?

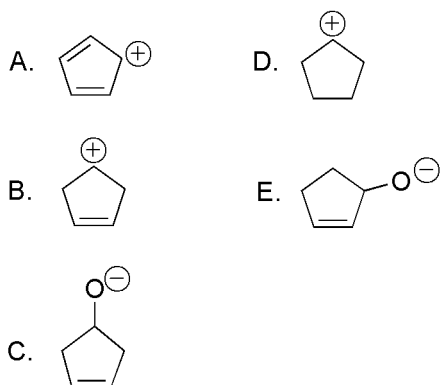

98. Treatment of benzoic acid with thionyl chloride followed by addition of ethanol gives which of the following as the major product?

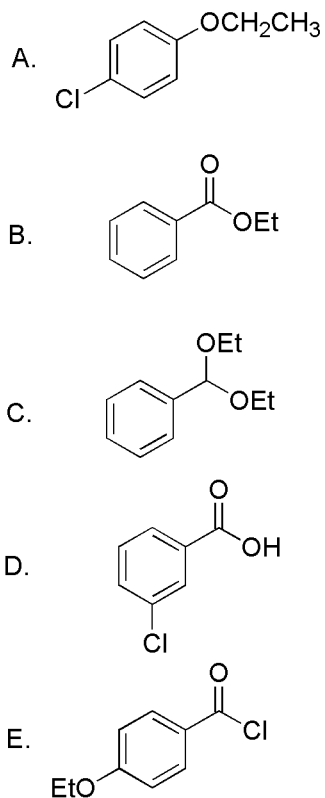
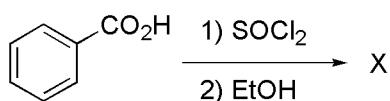

99. What is the major product (B) of the following reaction sequence?

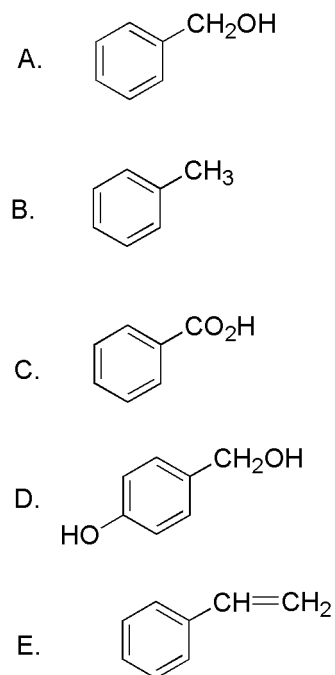
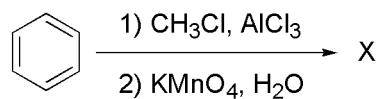

100. The most acidic hydrogen(s) in the following compounds are attached to which of the following carbons?

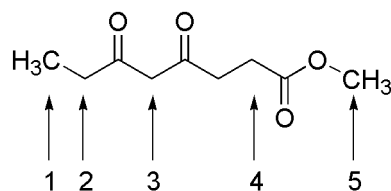

- A. 1
B. 2
C. 3
D. 4
E. 5

Reading Comprehension Test
Sample Test
Time Limit: 15 minutes

Ionizing Radiation:

Risk and Benefit

X radiation is a form of energy that was discovered by the German physicist, Wilhelm Conrad Roentgen in 1895. Like visible light, radiowaves, and microwaves, X-rays belong to a group of radiations known as the electromagnetic spectrum. Electromagnetic radiations are comprised of units of pure energy called photons, or quanta, that have no mass or weight. This is quite different from corpuscular, or particular, radiations that are comprised of measurable subatomic particles. These subatomic particles include the alpha particle, or helium radical; the beta particle, or electron; as well as protons and neutrons.

All photons of electromagnetic radiation travel in direct lines in an oscillatory wave motion known as longitudinal waves at the speed of 300,000 kilometers per second. An example of the oscillatory movement of longitudinal waves can be seen in the compressions generated when a coiled spring is tapped sharply at one end. This is different from the successive crests that are seen in the transverse waves that occur in water and in the plucking of a stringed instrument. While the wavelength of transverse waves is measured between successive crests, the wavelength for electromagnetic radiations is the distance between successive areas of compression.

Electromagnetic radiations of different wavelengths have different properties. At one end of the spectrum there are the very long wavelengths used in the transmission of radio messages. At the other end of the spectrum are the short wavelength radiations such as gamma radiations, which arise from naturally occurring unstable elements, and X-rays, which are similar in property to gamma radiations, but are man-made by bombarding a target material with electrons in an X-ray tube. For gamma and x radiations, the wavelengths are so small that they are measured in Angstrom units, where an Angstrom unit is 1/100,000,000 centimeter. The shorter the wavelength, the higher the energy and penetrating power of the photon and the higher the frequency of the waves.

It is the high frequency portion of the electromagnetic spectrum that is considered ionizing. Ionizing radiation has enough energy to displace electrons from an atom's orbit, leaving the atom charged. The electromagnetic radiations with enough energy to be ionizing are x and gamma radiations. If the ionized atoms or molecules are within living systems, there is the potential for biological harm. X-ray wavelengths are used in diagnostic radiology and range from approximately 0.1 to 0.5 Angstroms. This is the reason for the paradox that X-rays can cause cancer, can be used to help in the diagnosis of disease, and in high doses can be used to destroy cancer cells.

Radiation bioeffects can be divided into two basic types where relatively high doses of radiation are concerned. One category of effects requires a threshold dose be met before detectable change occurs. Such effects are termed non-stochastic, and are primarily a result of cell death. Examples are acute radiation syndrome and the development of cataracts. On the other hand, stochastic effects show statistical probability of occurrence as a function of dose, but no threshold cutoff for the effect. Examples of stochastic effects are carcinogenesis and genetic mutations.

Consideration of the potential benefits of an activity is involved in the decision of risk acceptability. Determining the risk-benefit ratio for diagnostic radiology is quite complicated. Risk is generally given in units of equivalent radiation dose, while the benefit is expressed in such terms as lives saved or disease cured. However, the risk from low-level radiation usually considers whole-body exposure, which is not generally the case for the diagnostic use of x radiation. Moreover, it is not easy to define the value of a life saved in units of dose equivalence. Because of these uncertainties, diagnostic radiation is to be regarded as a potentially noxious agent. Hence, radiological examination should be carried out only if it is likely that the information obtained will be useful for the clinical management of the patient.

The problem in evaluating the risk of cancer or mutation in human populations due to the diagnostic use of x radiation is that it is difficult to distinguish between disease resulting from the radiation and that which is spontaneous or due to other factors in the environment. The only way to assess the magnitude of the risk would be to determine the excess incidence of cancer or mutations in an irradiated population. Where the

excess incidence is expected to be small, extremely large populations and long periods of observation are required. This makes such cancer studies time-consuming and quite expensive. Similar considerations apply to the evaluation of risks from small doses of ionizing radiation of all human cancers and mutations. Hence, it has been common practice to use quantitative estimates and interpolations from observations of human and animal populations exposed to large radiation doses when attempting to make numeric estimates of the risks to humans from low doses of ionizing radiation.

In light of the uncertainty surrounding possible risks from the diagnostic use of X-rays, the International Commission on Radiological Protection has originated the concept of keeping exposure levels "as low as reasonably achievable," known as the ALARA Principle. The three key ways of minimizing exposure to radiation are minimizing the duration of exposure, maximizing the distance from the source, and using barriers such as leaded clothing or screens. As the intensity of the X-ray beam is inversely proportional to the square of the distance from the source (e.g. when the distance is doubled the intensity of the beam is reduced by a factor of four, when tripled it is reduced by a factor of nine...) the operator should be as far as possible from the X-ray machine if it is not possible to stand behind a barrier impregnable to the X-rays being used. By conscientious use of the ALARA Principle, the practitioners reduce risks for themselves, their staff, and their patients.

1. Which electromagnetic radiation has the longest wavelength?
 - A. Beta
 - B. Corpuscular
 - C. Gamma
 - D. Radiowave

2. Which of the following most closely resembles the wave motion for x radiation?
 - A. A coiled spring that has been sharply tapped at one end.
 - B. A plucked stretched string of a musical instrument.
 - C. A wave in water caused by disturbance from a fast moving motor boat.
 - D. A transverse wave form.

3. Which of the following measured wavelengths has the greatest number of waves per second?
 - A. 10 Angstroms
 - B. 10 millimeters
 - C. 10 centimeters
 - D. 10 meters

4. A helium radical is an example of a quanta.
Corpuscular radiations have no weight or mass.
 - A. Both statements are true.
 - B. Both statements are false.
 - C. The first statement is true, the second is false.
 - D. The first statement is false, the second is true.

5. What type of radiation is considered ionizing?
 - A. Gamma
 - B. Microwaves
 - C. Radiowaves
 - D. Visible light

6. What is another name for the beta particle?
 - A. Electron
 - B. Neutron
 - C. Photon
 - D. Quanta

7. It is difficult to distinguish between disease caused by radiation and that due to other factors.
Stochastic effects of radiation have no threshold cutoff for the effect.
 - A. Both statements are true.
 - B. Both statements are false
 - C. The first statement is true, the second is false.
 - D. The first statement is false, the second is true.

8. Which situation would be the most appropriate use of diagnostic radiology?
- An annual chest x-ray on a healthy 25-year-old.
 - An x-ray of a sprained ankle that shows no evidence of fracture.
 - A mammogram on a woman with a lump in her breast.
 - Prior to removal of a wooden splinter from a finger.
9. What is the range, in Angstroms, of the X-ray wavelengths used in diagnostic radiology?
- 0.1 to 0.5
 - 0.6 to 1.0
 - 1.5 to 3.0
 - 5 to 10
10. Which one is an example of the stochastic effect of radiation?
- Cataracts
 - Cell death
 - Acute radiation syndrome
 - Genetic mutation
11. What is the paradox of x radiation?
- It is used frequently but the risks are not well understood.
 - It is composed of long but high frequency waves.
 - It is similar to gamma radiation but it is non-ionizing.
 - It can both cause and cure cancer.
12. A radiologist starts a procedure standing 4 meters from the source of radiation but moves 3 meters closer to finish the procedure. The amount of radiation the radiologist received at the end of the procedure compared the beginning increased by what factor?
- 0.25
 - 3
 - 4
 - 9
 - 16
13. If doctors decided to use radiation treatment on cancer patients based on the formula $R=1/S$, where R is the risk factor and S is the projected survival of the patient in months, a patient with which R value would be most likely to receive treatment?
- 0.2
 - 0.3
 - 0.5
 - 1.00
14. While visiting a sick friend who has a radioactive implant, what would be an application of the ALARA Principle?
- Visiting for 60 minutes once a week rather than 30 minutes three times a week.
 - Put on a paper gown, hat, booties, and mask before going into the room.
 - Sitting in the chair near the door rather than the one near the bed.
 - Ask your friend to cover up with an extra blanket before you enter the room.
15. A patient with radiation burns was most likely exposed to a high dose of ionizing radiation over a short period of time.
- Non-stochastic effects of radiation area more serious problems for diagnostic radiology than are stochastic effects.
- Both statements are true.
 - Both statements are false
 - The first statement is true, the second is false.
 - The first statement is false, the second is true.

Physics Test

Sample Test

Time Limit: 50 minutes

Use the following working values for the physical constants:

Acceleration due to gravity on the surface of the earth: $g = 10 \text{ m/s}^2$

Speed of light in a vacuum: $c = 3.0 \times 10^8 \text{ m/s}$

Charge of an electron: $Q_e = 1.6 \times 10^{-19} \text{ coulomb}$

1. What is the magnitude of the resultant force, in Newtons, acting on an object that has two forces acting in the same direction having magnitudes of 15 Newtons and 25 Newtons and a third force acting perpendicular to the first two having a magnitude of 30 Newtons?
A. 5
B. 10
C. 40
D. 50
E. 70
2. The universal gravitational law can be written $F = Gm_1m_2/d^2$. Which of the following are the units of the constant G ?
A. $\text{kg}^2 \cdot \text{m}^2/\text{Newton}$
B. $\text{kg}^2/(\text{Newton} \cdot \text{m}^2)$
C. $1/\text{Newton}$
D. $\text{Newton} \cdot \text{kg}^2 \cdot \text{m}^2$
E. $\text{Newton} \cdot \text{m}^2/(\text{kg})^2$
3. A vector quantity is BEST described as having
A. a direction only.
B. a magnitude only.
C. units only.
D. a magnitude and a direction.
E. significant figures.
4. Carbon 14 is different than Carbon 12 because it has
A. 2 more protons.
B. 1 more proton and 1 more neutron.
C. 1 more proton and 1 more electron.
D. 2 more electrons.
E. 2 more neutrons.

5. Referring to the data plotted in the figure, what is the acceleration between time 0 and 5 s?

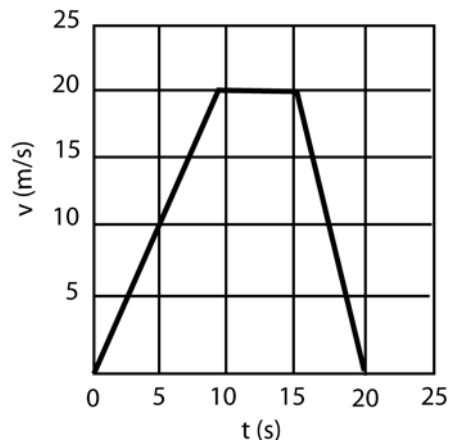

- A. $+ 2 \text{ m/s}^2$
B. $+ 25 \text{ m/s}^2$
C. 0 m/s^2
D. -2 m/s^2
E. -25 m/s^2
6. A magnifying glass is constructed when the lens is
A. converging and the object is located at twice the focal length.
B. converging and the object is between the lens and the focal point.
C. diverging and the object is at twice the focal length.
D. diverging and the object is between the lens and the focal point.

7. Which diagram best represents the velocity as function of the time of a ball thrown vertically upward? (See figure below.)

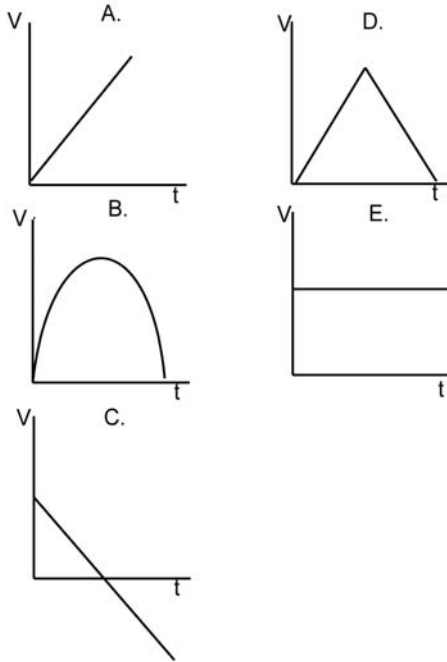

- A. A
B. B
C. C
D. D
E. E

8. How many seconds does it take a car traveling 4 m/s to increase its speed to 6 m/s if it has an acceleration of 2 m/s²?

- A. 1
B. 2
C. 3
D. 4
E. 5

9. The acceleration vector is always

- A. parallel to the displacement vector.
B. parallel to the velocity vector.
C. parallel to the resultant force vector.
D. perpendicular to the velocity vector.
E. perpendicular to the resultant force vector.

10. A 50-kg girl pulls a 20-kg wagon with a force of 10 Newtons. The wagon accelerates at 2 m/s². What is the force, in Newtons, exerted BY the wagon ON the girl?

- A. 140
B. 100
C. 40
D. 20
E. 10

11. A small girl applies a horizontal force of 2 Newtons to a 10-Newton box which slides across the floor with a constant speed of 3 m/s. What is the frictional force, in Newtons, by the floor on the box?

- A. 2
B. 6
C. 8
D. 10
E. 12

12. A satellite of mass 200kg completes a circular orbit of the Earth in 120 minutes. A 400 kg satellite is then put into orbit at the same height above the Earth. Which of the following represents the time, in minutes, for the 400 kg satellite to complete a circular orbit

- A. 60
B. 120
C. 180
D. 240
E. 360

13. Atmospheric pressure is very nearly 100 kPa. A sealed container of air at 1 atmospheric pressure has a door 1 m wide and 2 m high. This door is very hard to open during HIGH pressure days. If the atmospheric pressure on the outside of the container is just 1 percent greater than on the inside, then what added force in Newtons is required to open the container door?

- A. 100
B. 200
C. 2,000
D. 10,000
E. 20,000

14. An elevator weighing 480 Newtons is supported by a light, vertical cable which exerts a constant force on the elevator, causing the elevator to accelerate upward. Which of the following is the tension, in Newtons, in the cable?

- A. Greater than 480
- B. Less than 480
- C. Equal to 480
- D. Data is insufficient to determine the answer
- E. 0

15. A massless rod in the sketch below is free to rotate about an axis through point O, at the right end of the rod. To maintain equilibrium, which of the following must force F, in Newtons, equal?

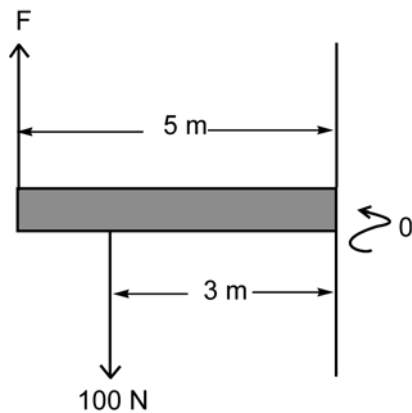

- A. 20
- B. 40
- C. 60
- D. 100
- E. 120

16. A ball is thrown horizontally at 20m/s from the top of a building and strikes the level ground 50 m from the building. Approximately how many meters high is the roof of the building?

- A. 12.5 m
- B. 24.5 m
- C. 31 m
- D. 50 m
- E. 62 m

17. A girl exerted 150 Newtons to lift a barbell 2.0 m in 4.0 s. If she did the same thing in 8.0 s, the work done on the barbell by the girl would be

- A. one fourth as great.
- B. one half as great.
- C. the same.
- D. twice as great.
- E. four times as great.

18. A block of mass 1 kg, initially at rest, is hit by another block of mass 2 kg, moving initially with a speed of 12 m/s. After the collision, the two blocks move forward as a single composite body. Which of the following is the speed, in m/s, of the composite body?

- A. 3
- B. 4
- C. 6
- D. 8
- E. 10

19. If friction is neglected, a 2-kg object that has fallen 10 m.

- A. has gained potential energy.
- B. has lost kinetic energy.
- C. will have a constant mechanical energy.
- D. has lost 20 Joules of potential energy.
- E. has gained 20 Joules of kinetic energy.

20. Which of the following has the largest momentum?

- A. A 30,000-kg railroad car traveling at 1 m/s
- B. A 200-kg person running at 3 m/s
- C. A 1-g bee flying at 5 m/s
- D. A 2,000-kg car traveling at 10 m/s
- E. A 20-g bullet traveling at 1,000 m/s

21. The amplitude of a body undergoing simple harmonic motion is doubled. Which of the following is also doubled?

- A. Maximum speed
- B. Frequency
- C. Mass
- D. Total energy
- E. Period

- 22.** If an 80-cm-long spring requires 10 Newtons to stretch 5 cm, how much force, in Newtons, will be needed to stretch the same spring by 8 cm?
- 8
 - 16
 - 24
 - 50
 - 80
- 23.** An AM radio station broadcasts at a frequency of 600 kHz. If these waves have a speed of 3×10^8 m/s, then what is their wavelength in meters?
- .0020
 - 500
 - 5000,000
 - 1.80×10^{11}
 - 1.80×10^{14}
- 24.** In a vacuum, radio waves, microwaves, and x-rays all have the same
- period.
 - frequency.
 - wavelength.
 - energy.
 - speed.
- 25.** A uniform block of mass 180 g that is $10 \times 9 \times 3$ cm is to be placed in a liquid of density 0.900 g/cm^3 . The block will
- sink in the liquid.
 - just float in the liquid with none of its volume above the surface of the liquid.
 - float in the liquid with more than $1/2$ of its volume above the surface of the liquid.
 - float in the liquid with less than $1/3$ of its volume above the surface of the liquid.
 - float in the liquid with all of its volume above the surface of the liquid.
- 26.** The water in a swimming pool is 3.0 m deep. During the day, the atmospheric pressure increases by $2.0 \times 10^3 \text{ N/m}^2$. During this same period, the pressure at the bottom of the pool, in N/m^2 , will
- not change.
 - increase by 1.0×10^7 .
 - increase by 6.0×10^3 .
 - increase by 6.0×10^4 .
 - increase by 2.0×10^3 .
- 27.** A 600-N force is applied to a safe full of gold which weighs 2000 N's but it does not move. What is the friction force exerted by the floor to the safe?
- < 600 N
 - 600 N
 - > 600 N but < 2000 N
 - 2000 N
 - > 2000 N
- 28.** If an object is displaced a small distance from an equilibrium position and returns to that position after being released, then which of the following best describes this equilibrium position?
- Stable equilibrium position
 - Neutral equilibrium position
 - Unstable equilibrium position
 - Position of positive equilibrium
 - Position of negative equilibrium
- 29.** A thin lens produces a virtual image which is smaller than the object. It must be that the
- object must be inside the focal point of a converging lens.
 - object must be outside the focal point of a converging lens.
 - lens must be a diverging lens.
 - object must be infinitely far from a converging lens.
 - object must be far from the optical axis of a converging lens.

30. An object initially moving with speed 5m/s has acceleration -2m/s^2 . Which of the following graphs best represents the object's velocity as a function of time?

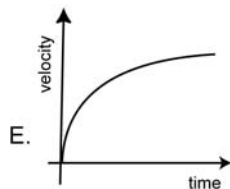
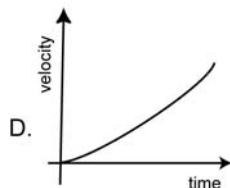
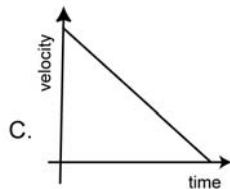
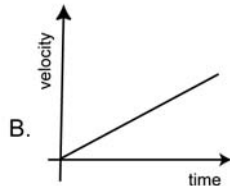
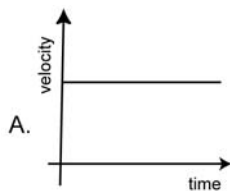

31. The Kelvin temperature of an ideal gas is proportional to the average
- momentum of a molecule in the gas.
 - angular momentum of a molecule in the gas.
 - kinetic energy of a molecule in the gas.
 - net force on a molecule in the gas.
 - moment of inertia of a molecule in the gas.

32. Water boils at 100°C at sea level at atmospheric pressure. At higher pressure, water will boil at (a)
- higher temperature.
 - lower temperature.
 - 100°C
 - 0°C
 - 273K

33. Which of the following is the cost of lighting a 100-W lamp for 10 hours at $\$0.10$ per kilowatt-hour?
- $\$0.01$
 - $\$0.10$
 - $\$0.50$
 - $\$1.00$
 - $\$10.00$

34. A negatively charged insulator is brought near to, without touching, the left side of an uncharged, solid metal sphere. Which of the following figures best describes the charge distribution on the sphere with the insulator held in place?

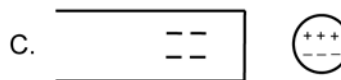
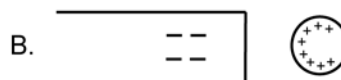

35. A 12-volt battery with an internal resistance of $1\text{-}\Omega$ resistor. Which of the following is the current in amperes that flows in the circuit.

- A. 4
- B. 3
- C. 9
- D. 12
- E. 48

36. Where in the circuit should a voltmeter be placed to measure the voltage across R_3 ?

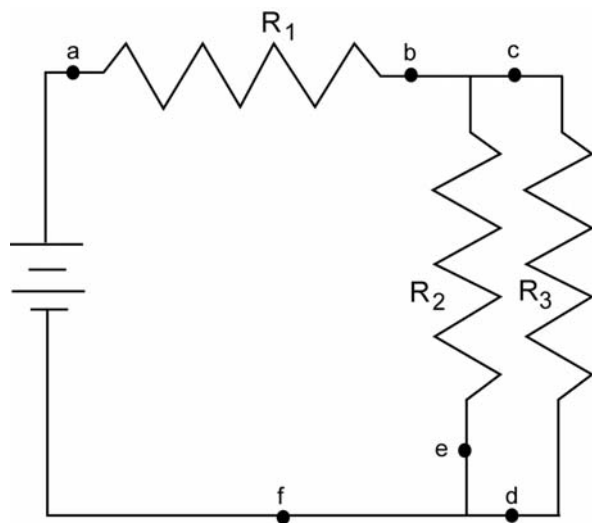

- A. From point a to point b
- B. From point c to point d
- C. In series at point e
- D. In series at point f
- E. In series at point d

37. A long straight horizontal wire with a current in it produces a magnetic field that

- A. points radially away from the wire.
- B. has the same magnitude at all locations.
- C. points in the same direction above and below the wire.
- D. at any point is perpendicular to the plane containing that point and the wire.
- E. points radially toward the wire.

38. As red light goes from the air into water at an angle of incidence of 40° , which of the following necessarily remains constant?

- A. Wavelength of the light
- B. Speed of the light
- C. Polarization of the light
- D. Frequency of the light
- E. Direction of travel of the light

39. What is the focal length in cm of a lens that produces an image 30 cm behind it when the object is placed 6 cm in front of it?

- A. 7.5
- B. 36
- C. 5.0
- D. 24
- E. 18.0

40. Six identical bulbs are connected to a battery as shown. What is the correct ranking of the brightness for the bulbs?

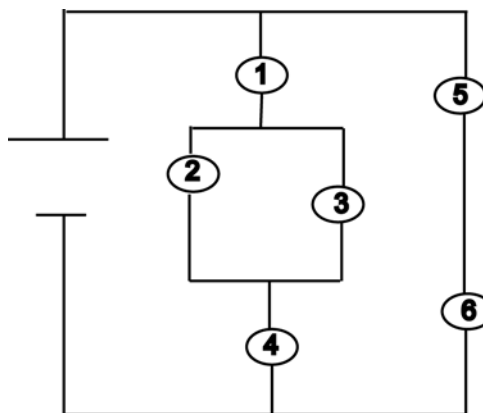

- A. $1 = 4 > 5 = 6 > 2 = 3$
- B. $5 = 6 > 1 = 4 > 2 = 3$
- C. $1 = 4 > 2 = 3 > 5 = 6$
- D. $1 = 4 > 5 = 6 = 2 = 3$
- E. $1 = 2 = 3 = 4 = 5 = 6$

Quantitative Reasoning Test
QRT – Test Number 51

1. At 7:00 a.m. a student leaves his home in his automobile to drive to school 28 miles away. He averages 50 mph until 7:30 a.m. when his car breaks down. The student has to walk and run the rest of the way. If he wants to arrive at school at 8:00 a.m. how fast, in mph, must he travel on foot?
- A. 3
B. 4
C. 5
D. 6
E. 7
2. A theater charges \$5.00 admission for adults and \$2.50 for children. At one showing 240 admissions brought a total of \$800. How many adults attended the showing?
- A. 40
B. 80
C. 120
D. 160
E. 266
3. The perimeter of a square is 20. Which of the following represents the area?
- A. 5
B. 10
C. 20
D. 25
E. 100
4. If $0 \leq x \leq 12$ and $-2 \leq y \leq 9$, then $\frac{3x - 4}{4 + 5y^2}$ is as large as possible when
- A. $x = 12$ and $y = 9$.
B. $x = 12$ and $y = 0$.
C. $x = 12$ and $y = -12$.
D. $x = 0$ and $y = 9$.
E. $x = 0$ and $y = 0$.
5. Evaluate the expression $\frac{1}{4} + \frac{3}{8} - \frac{6}{16} - \frac{8}{32}$.
- A. $\frac{7}{16}$
B. $\frac{1}{32}$
C. $\frac{1}{8}$
D. $\frac{1}{4}$
E. 0
6. Express the product $(2x + 5y)^2$ in simple form.
- A. $4x^2 + 25y^2$
B. $4x^2 + 20xy + 25y^2$
C. $4x^2 + 10y + 25y^2$
D. $4x^2 - 20xy + 25y^2$
E. $4x + 25y$
7. A student received test grades of 83, 90, and 88. What was her grade on a fourth test if the average for the four tests is 84?
- A. 85
B. 80
C. 75
D. 70
E. 65
8. A rectangular room is 3 meters wide, 4 meters long and 2 meters high. How far is it from the northeast corner at the floor to the southwest corner at the ceiling?
- A. $\sqrt{29}$ meters
B. $\sqrt{11}$ meters
C. $\sqrt{9}$ meters
D. 9 METERS
E. 5 METERS

9. If an electron has a mass of 9.709×10^{-31} kg, and a proton has a mass of 1.672×10^{-27} kg, approximately how many electrons are required to have the same mass as one proton?
- A. 150,000
 B. 1,800
 C. 5.4×10^4
 D. 5.4×10^{-4}
 E. 15×10^{-58}
10. The introduction of a new manufacturing process will effect a savings of \$1,450.00 per week over the initial 8-week production period. New equipment, however, will cost $\frac{1}{4}$ of the total savings. How much did equipment cost?
- A. \$11,600.00
 B. \$2,900.00
 C. \$725.00
 D. \$362.50
 E. \$181.25
11. An investment is made at r percent compounded annually, at the end of n years it will have grown to $A = P(1 + r)^n$. An investment made at 16% compounded annually. It grows to \$1,740 at the end of the year. How much was originally invested?
- A. \$150
 B. \$278.40
 C. \$1,461.60
 D. \$1,500
 E. \$1,700
12. What is $\frac{1}{4}\%$ of 200?
- A. 0.05
 B. 0.5
 C. 5
 D. 12.5
 E. 50
13. If $2x + y = 7$ and $x - 4y = 4$, then x equals which of the following?
- A. $-\frac{15}{9}$
 B. $-\frac{1}{9}$
 C. $\frac{7}{16}$
 D. $\frac{11}{9}$
 E. $\frac{32}{9}$
14. What part of an hour is 6 seconds?
- A. $\frac{1}{600}$
 B. $\frac{1}{10}$
 C. $\frac{1}{360}$
 D. $\frac{1}{60}$
 E. $\frac{1}{5}$
15. If $\frac{1}{3} + \frac{5}{(x - 1)} = 8$, then which of the following is the value of x ?
- A. $\frac{8}{13}$
 B. $\frac{8}{5}$
 C. $\frac{38}{25}$
 D. $\frac{38}{23}$
 E. 38

16. Which line is perpendicular to the x-axis?

- A. $x = 3$
- B. $y = 3$
- C. $x = y$
- D. $x = y/3$
- E. $y = x/3$

17. The dental hygienist at a certain office is paid H dollars a week. The dental assistant works 36 hours a week at A dollars per hour, and the receptionist works 40 hours a week and receives R dollars every other week. Which of the following represents the weekly payroll for these three employees?

- A. $\frac{H}{3} + 36A + \frac{40R}{3}$
- B. $H + 36A + \frac{R}{2}$
- C. $\frac{H}{3} + 12A + \frac{R}{6}$
- D. $5H + 36 + 20R$
- E. $\frac{H}{3} + 12A + 40R$

18. The value of $\cos(\pi/3)$ equals the value of

- A. $-\cos(2\pi/3)$.
- B. $\cos(2\pi/3)$.
- C. $\cos(6\pi/3)$.
- D. $-\cos(5\pi/3)$.
- E. $\cos(4\pi/3)$.

19. Three consecutive odd numbers have a sum of 51. What is the largest of these numbers?

- A. 15
- B. 17
- C. 18
- D. 19
- E. 21

20. Which of the following is the value of A, if

$$50\left(\frac{A}{100}\right) = 2A^2?$$

- A. 25
- B. 1
- C. $\frac{5}{2}$
- D. $\frac{1}{4}$
- E. $\frac{1}{2}$

21. Five eighths of the employees in a certain company are male. One fifth of these males are single. What percentage of the employees in the company are single males?

- A. 12.5
- B. 20.0
- C. 25.0
- D. 32.0
- E. 62.5

22. If x pens costs 75 cents and y pencils cost 57 cents, then which equation below can be used to find the cost of 2 pens and 3 pencils?

A. $2\left(\frac{75}{x}\right) + 3\left(\frac{57}{y}\right)$

B. $\frac{3x}{75} + \frac{2y}{57}$

C. $\frac{75}{2x} + \frac{57}{3y}$

D. $2\left(\frac{x}{75}\right) + 3\left(\frac{y}{57}\right)$

E. $3\left(\frac{75}{x}\right) + 2\left(\frac{57}{y}\right)$

23. Which of the following is the value of the expression $\frac{|14 - 3| - |7 - 16|}{3|(-2) + 1|}$?

- A. $-\frac{20}{3}$
- B. $-\frac{2}{3}$
- C. 0
- D. $\frac{2}{3}$
- E. $\frac{20}{3}$

24. A tank can be filled by a pipe in 30 minutes and emptied by another pipe in 50 minutes. How many minutes will it take to fill the tank if both pipes are open?

- A. 45
- B. 60
- C. 75
- D. 80
- E. 100

25. If $\left(\frac{4}{5}\right)x = \left(\frac{2}{5}\right)y$, then which of the following is equal to $\frac{y}{x}$?

- A. $\frac{1}{2}$
- B. $\frac{2}{5}$
- C. $\frac{25}{8}$
- D. 2
- E. 3

26. Which of the following would NOT result in a straight line?

- A. $x = \frac{1}{y}$
- B. $x = 2y + 5$
- C. $x = \frac{(y + 6)}{(2)}$
- D. $x = 5 - y$
- E. $x = 4(x + 3y)$

27. If $\frac{2}{x} + \frac{3}{5} = \frac{4}{3}$, then which of the following is the value of x?

- A. $\frac{30}{11}$
- B. $\frac{30}{29}$
- C. $\frac{11}{30}$
- D. $-\frac{11}{6}$
- E. $-\frac{5}{2}$

28. Optometry school applicants decreased by 25% during a 4-year period. During the same time, the number of first-year openings in optometry school increased by 12%. If the ratio of applicants to first-year student openings had been 3 to 1, then which of the following would be the approximate ratio at the end of the 4-year period?

- A. 1.5 to 1
- B. 2 to 1
- C. 3 to 2
- D. 4 to 3
- E. 6 to 5

29. If $\sqrt{x - 25} = 7 - 5$, then which of the following is the value of x ?

- A. 4
- B. 27
- C. 29
- D. 49
- E. 729

30. Two cars start at the same point and travel north and west at the rate of 24 and 32 mph respectively. How far apart are they at the end of 2 hours?

- A. 64
- B. 80
- C. 112
- D. 116
- E. 100

31. Right triangle ABC with right angle at C and $AB = 6$, $BC = 3$, find AC.

- A. 3
- B. 6
- C. 27
- D. 33
- E. $3\sqrt{3}$

32. When each of the sides of a square is increased by 1 yard, the area of the new square is 53 square yards more than that of the original square. What is the length of the sides of the original square?

- A. 25
- B. 26
- C. 27
- D. 52
- E. 54

33. Evaluate: $3(2)^2 + \sqrt{25} - (-2)^3$

- A. 9
- B. 24
- C. 25
- D. 33
- E. 76

34. Which of the following is the length of the line segment BC, if $AB = 14$, $AD = 5$ and angle $BAD = 30^\circ$

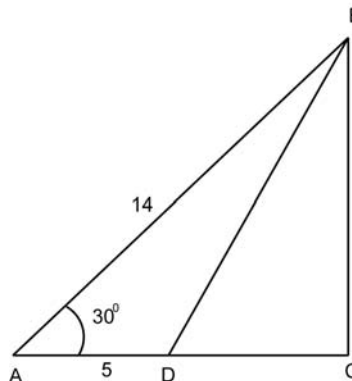

- A. $\sqrt{221}$
- B. $\sqrt{171}$
- C. $7\sqrt{3}$
- D. 7
- E. 9

35. A bowl contains 7 green and 3 red marbles. What is the probability that two marbles selected at random from this bowl without replacement are both red?

- A. $\frac{1}{15}$
- B. $\frac{9}{100}$
- C. $\frac{21}{100}$
- D. $\frac{47}{90}$
- E. $\frac{6}{10}$

36. Maria has a number of dimes and quarters whose total value is less than \$9.00. There are twice as many dimes as quarters. At most, how many quarters could she have?
- A. 14
 - B. 15
 - C. 19
 - D. 20
 - E. 35
37. The numbers (1,2,3,6) have an average (arithmetic mean) of 3 and a variance of 3.5. What is the average (arithmetic mean) and variance of the set of numbers (3,6,9,18)?
- A. 9, 31.5
 - B. 3, 10.5
 - C. 3, 31.5
 - D. 6, 7.5
 - E. 9, 27.5
38. A ceiling 6 feet by 7 feet can be painted for \$52. Find the cost of painting a ceiling 18 feet by 21 feet, all things being equal except the dimensions.
- A. \$104
 - B. \$126
 - C. \$156
 - D. \$378
 - E. \$468
39. A container in the form of a rectangular solid is 10 feet long, 9 feet wide, and 2 feet deep. The container is filled with a liquid weighing 100 pounds per cubic foot. What is the weight of the liquid in the container in pounds?
- A. 90
 - B. 180
 - C. 1,800
 - D. 9,000
 - E. 18,000
40. It takes 5 hours for a qualified typist to complete a report. Coffee break begins at 10:15 a.m. It is now 9:55 a.m. How much of the task can the typist be expected to complete by the coffee break?
- A. $\frac{1}{8}$
 - B. $\frac{1}{25}$
 - C. $\frac{1}{3}$
 - D. $\frac{1}{5}$
 - E. $\frac{1}{15}$

Optometry Admission Test Preparation Materials Answer Keys

SURVEY OF THE NATURAL SCIENCES

1. E	26. A	51. B	76. A
2. C	27. C	52. B	77. D
3. A	28. C	53. D	78. B
4. D	29. B	54. D	79. E
5. C	30. B	55. E	80. E
6. C	31. A	56. B	81. E
7. A	32. B	57. A	82. D
8. E	33. D	58. E	83. D
9. E	34. B	59. A	84. B
10. C	35. D	60. A	85. C
11. C	36. B	61. A	86. E
12. D	37. A	62. C	87. B
13. D	38. A	63. C	88. A
14. D	39. C	64. C	89. D
15. E	40. D	65. B	90. C
16. E	41. C	66. D	91. E
17. B	42. C	67. B	92. A
18. A	43. E	68. D	93. C
19. E	44. D	69. D	94. C
20. D	45. D	70. E	95. B
21. D	46. E	71. C	96. B
22. A	47. A	72. B	97. A
23. D	48. C	73. C	98. B
24. B	49. A	74. A	99. C
25. B	50. D	75. D	100. C

PHYSICS TEST

1. D	11. A	21. A	31. C
2. E	12. B	22. B	32. A
3. D	13. C	23. B	33. B
4. E	14. A	24. E	34. E
5. A	15. C	25. D	35. B
6. B	16. C	26. E	36. B
7. C	17. C	27. B	37. D
8. A	18. D	28. A	38. D
9. C	19. C	29. C	39. C
10. E	20. A	30. C	40. B

READING COMPREHENSION TEST

1. D	6. A	11. D
2. A	7. A	12. E
3. A	8. C	13. A
4. B	9. A	14. C
5. A	10. D	15. C

QUANTITATIVE REASONING TEST

1. D	16. A	31. E
2. B	17. B	32. B
3. D	18. A	33. C
4. B	19. D	34. D
5. E	20. D	35. A
6. B	21. A	36. C
7. C	22. A	37. A
8. A	23. D	38. E
9. B	24. C	39. E
10. B	25. D	40. E
11. D	26. A	
12. B	27. A	
13. E	28. B	
14. A	29. C	
15. D	30. B	

ESTIMATING YOUR STANDARD SCORE

The Raw Score/Standard Score Conversion Table is designed to help you estimate the standard score that you would have received on the various tests if you had actually taken them. On the OAT, eight standard scores are reported. There are scores reported for Quantitative Reasoning, a separate 40-item test; Reading Comprehension, a separate 40-item test; Biology, the first 40 items of the Survey of the Natural Sciences; General Chemistry, items 41-70 on the Survey of the National Sciences; Organic Chemistry, items 71-100 on the Survey of Natural Sciences; Physics, a separate 40-item test; Total Science score, combining the Survey of the Natural Sciences (100 items) and Physics (40 items); and an Academic Average.

The following procedure will allow you to estimate your standard score.

1. Take the practice test under timed conditions to approximate the actual test administration.
2. There is no penalty for attempting an item and getting it wrong. You should attempt every item, eliminating as many incorrect answers as possible when you are not sure of the correct response.
3. Score the test using the answer key on page 39. Assign 1 point for every item answered correctly and 0 points for every item answered incorrectly.
4. Add up all the points on a test. This is your raw score.
5. The next step is to convert your raw score to a standard score. The standard scores on the OAT are reported on a scale from 200 to 400. The mean of the test is approximately 300 but varies during various testing periods depending on the distribution of ability in the examinees taking each test.

To find your standard score, locate the appropriate column for the test you just scored on the Raw Score/Standard Score Conversion Table.

6. Locate your raw score on that test in this column.
7. Go across that row to the left-hand column headed "STD Score" to find your standard score.

For example, if you answered 31 items correctly on the Biology Test, look to the column labeled BIO and go down that column until you find the score range that includes "31", i.e., 30-31. Then proceed across that row to the column labeled "STD Score" on the left. The row containing 30-31 for BIO corresponds to a standard score of 360 for that test.

This procedure can also be used for the Quantitative Reasoning Physics, Reading Comprehension, General Chemistry and Organic Chemistry Tests.

8. To find your Total Science score, add together your raw scores on Biology, General Chemistry, Organic Chemistry and Physics. The maximum raw score is 140. (Please do not add your standard scores together.)
9. In the column labeled "Total Science" find the row that contains your raw score for the sum of four science tests.
10. Go across the row to the left column to your Total Science Standard score.

For example if you answered 21 items correctly on the Biology, 14 on the General Chemistry, 13 on Organic Chemistry and 25 on Physics, your total science raw score would be $21 + 14 + 13 + 25$ or 73.

Next, find the score range in the "Total Science" column that contains "73", i.e., the eleventh row down when the range is 69-73. Proceed left across that row to the "STD Score" column. In this example, the standard score for a raw score of 73 on the Total Science test is 300.

11. The Academic Average reported on the OAT is the arithmetic average of six standard scores: Quantitative Reasoning (QRT), Reading Comprehension (RCT), Biology (BIO), General Chemistry (GEN CHEM), Organic Chemistry (ORG CHEM) and Physics (PHYS). Therefore, if your standard scores on the six tests were:

QRT	290
RCT	270
BIO	330
GEN CHEM	350
ORG CHEM	300
PHYS	360

$$1,900 \div 6 = 316.67$$

the sum of those six scores would be 1,900. Dividing this total by six yields a score 316.67. Because the OAT scores are reported only in intervals of 10 points, this would be rounded up to a score of 320. If the average had been 314.33, then the score would have been rounded down to 310.

RAW SCORE-STANDARD SCORE CONVERSIONS TEST PREPARATION MATERIALS
--

STD SCORE	QRT	RCT *	BIO	GEN CHEM	ORG CHEM	PHY	TOTAL SCI
400	35-40	14-15	36-40	29-30	26-30	37-40	118-140
390	33-34	-	35	28	25	36	115-117
380	32	13	33-34	27	24	34-35	110-114
370	30-31	-	32	25-26	23	33	105-109
360	28-29	12	30-31	24	22	31-32	99-104
350	27	-	29	23	20-21	30	93-98
340	25-26	11	28	21-22	19	29	89-92
330	24	-	27	19-20	16-18	27-28	84-88
320	23	-	25-26	17-18	14-15	25-26	79-83
310	21-22	10	23-24	15-16	13	24	74-78
300	19-20	9	22	14	11-12	21-23	69-73
290	18	-	20-21	13	10	20	64-68
280	17	8	19	11-12	9	19	60-63
270	15-16	-	17-18	10	8	17-18	55-59
260	13-14	-	15-16	8-9	7	16	51-54
250	-	7	14	7	6	15	47-50
240	12	-	13	6	-	14	44-46
230	11	6	12	-	5	13	41-43
220	9-10	-	11	5	4	11-12	37-40
210	8	5	8-10	4	3	10	34-36
200	0-7	0-4	0-7	0-3	0-2	0-9	0-33

* The actual Reading Comprehension Test will have 40 test questions based on three reading passages.